

U.S. Customary Units

RCR Multiple Unit Assemblies
 3-1/4" to 3-1/2" Hanger rod diameter
 46000-66000 pound capacity

E* refers only to the uppermost blocking position.
 Downward travel increases E dimension directly.

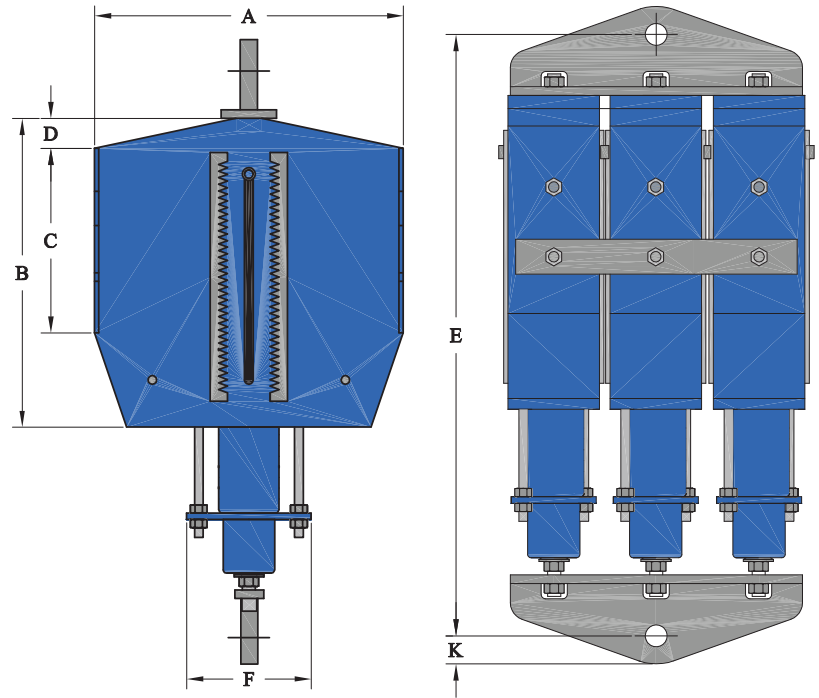
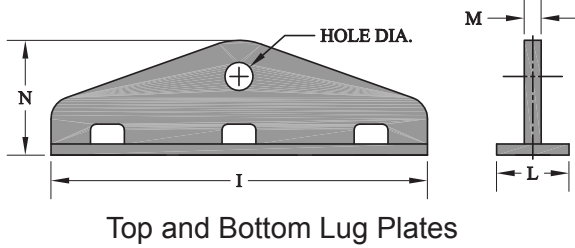

RILCO CAM ROLLER™ Identifier	A	B	C	D	E*	F	H	I	K	L	M	N	Hole Dia.	Est. Unit Wt lbs.	Rod Diameter
RCR 46000-12	49	44	29.25	5	105.75	16.5	36.75	33.75	4.25	3.25	1.375	12.25	3.375	5225	3-1/4 UNC
RCR 46000-18	51.25	64	33.50	9.75	125.5	16.5	37.50	34.25	4.25	3.25	1.375	12.25	3.375	6770	3-1/4 UNC
RCR 52000-3	33.75	23	13	2	51.5	15.25	36.75	33.75	4.25	3.25	1.375	12.25	3.375	2110	3-1/4 UNC
RCR 52000-6	39	28.25	13.50	8.5	68.5	15.25	36.75	33.75	4.25	3.25	1.375	12.25	3.375	2790	3-1/4 UNC
RCR 55000-12	50.5	37.75	15	15	94.25	18	40.25	36.75	4.75	3.50	1.375	13.75	3.875	4950	3-1/2 UNC
RCR 58000-18	53.25	63.75	31.50	11.5	132.25	18	41.00	37.50	4.75	3.50	1.375	13.75	3.875	7975	3-1/2 UNC
RCR 66000-3	35.75	24.75	13.75	2	56	17.25	40.25	36.75	4.75	3.50	1.375	13.75	3.875	2675	3-1/2 UNC
RCR 66000-6	45	31	14	9.75	72.75	17.25	40.25	36.75	4.75	3.50	1.375	13.75	3.875	3610	3-1/2 UNC
RCR 66000-12	51.25	43	23	9.75	111	18	41.00	37.50	4.75	3.50	1.375	13.75	3.875	6190	3-1/2 UNC

All dimensions shown are in inches U.N.O.